

V-Drive economy – Economical servo worm

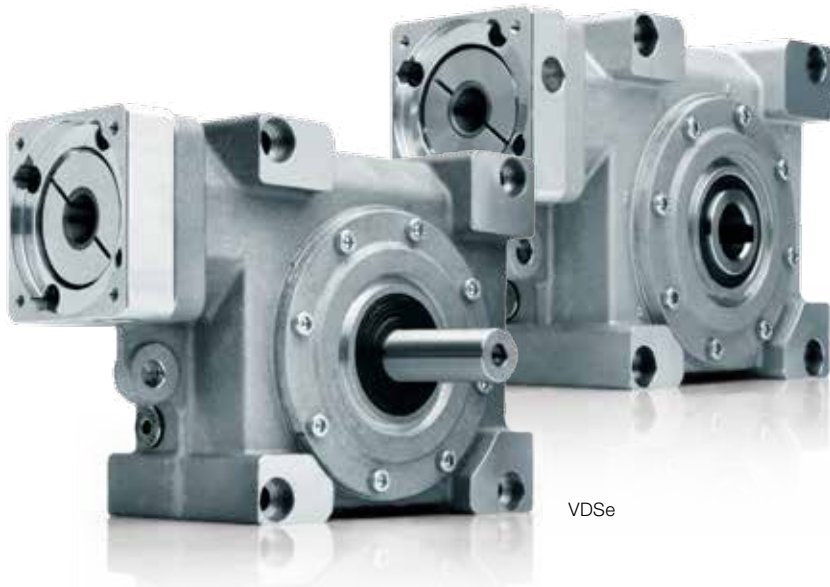

Low backlash servo worm gearheads with output shaft and hollow shaft. The V-Drive economy impresses with its high power density and medium torsional backlash. It is especially suitable for economical applications in continuous operation.

VDHe

VDSe

Quick size selection

V-Drive economy (example for $i = 28$)
 For applications in cyclic operation ($DC \leq 60\%$) or continuous operation ($DC \geq 60\%$)

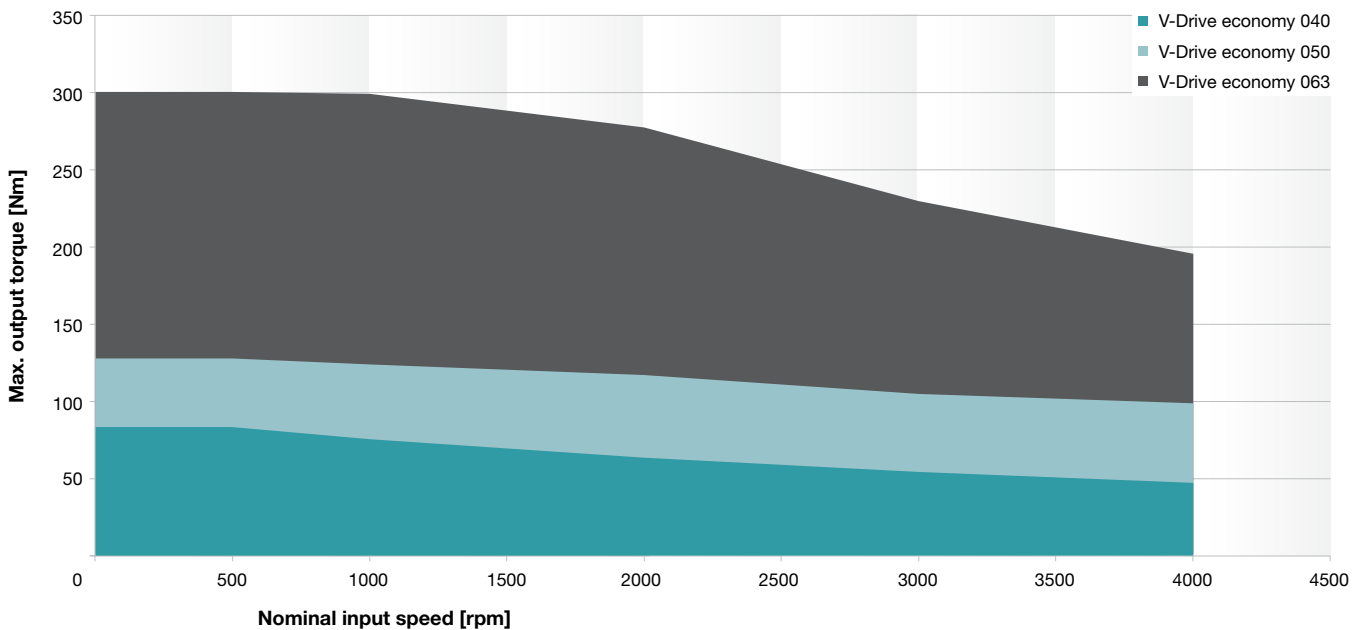

Versions and Applications

Features	VDHe with smooth/keyed hollow shaft page 344	VDSe with smooth/keywayed solid shaft page 350
Power density	••	••
Smooth-running	•••	•••

Product features

Ratios	4 – 40	4 – 40
Torsional backlash [arcmin]	≤ 8	≤ 8
Output type		
Smooth output shaft		•
Keywayed output shaft		•
Hollow shaft interface Connected via shrink disc	•	
Hollow shaft interface, rear side Connected via shrink disc	•	
Shaft on both sides		•
Input type		
Motor mounted version	•	•
Type		
Food-grade lubrication	•	•
Corrosion resistant ^{a)}	•	•
Accessories		
Coupling		•
Rack		•
Pinion		•
Shrink disc	•	

^{a)} Please contact WITTENSTEIN alpha

Right-angle gearheads
Economy

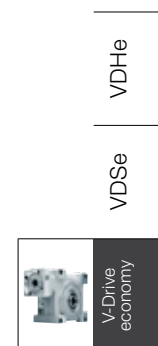

VDH economy 040 1-stage

			1-stage							
Ratio	<i>i</i>		4	7	10	16	28	40		
$n_{IN}=500$ rpm	T_{2Max}	Nm	60	75	76	79	83	76		
		in.lb	531	664	673	699	735	673		
	T_{2Servo}	Nm	17	24	25	26	29	25		
		in.lb	150	212	221	230	257	221		
	η	%	93	90	88	82	73	67		
$n_{IN}=1000$ rpm	T_{2Max}	Nm	45	60	68	72	75	70		
		in.lb	398	531	602	637	664	620		
	T_{2Servo}	Nm	19	26	28	29	32	28		
		in.lb	168	230	248	257	283	248		
	η	%	94	92	90	86	77	73		
$n_{IN}=2000$ rpm	T_{2Max}	Nm	35	50	54	59	63	60		
		in.lb	310	443	478	522	558	531		
	T_{2Servo}	Nm	19	26	28	29	33	29		
		in.lb	168	230	248	257	292	257		
	η	%	96	94	92	88	81	77		
$n_{IN}=3000$ rpm	T_{2Max}	Nm	30	42	46	51	53	52		
		in.lb	266	372	407	451	469	460		
	T_{2Servo}	Nm	19	26	28	29	32	28		
		in.lb	168	230	248	257	283	248		
	η	%	96	95	93	90	83	79		
$n_{IN}=4000$ rpm	T_{2Max}	Nm	28	36	40	44	47	46		
		in.lb	248	319	354	389	416	407		
	T_{2Servo}	Nm	19	25	27	28	31	27		
		in.lb	168	221	239	248	274	239		
	η	%	96	95	94	91	84	81		
Emergency stop torque	T_{2Not}	Nm	118	126	125	129	134	122		
in.lb		1044	1115	1106	1142	1186	1080			
Max. input speed	n_{1Max}	rpm	6000							
Mean no load running torque ^{a)} <small>(With $n_{IN}=3000$ min⁻¹ and 20° C gear temperature)</small>	T_{012}	Nm	0,8	0,7	0,5	0,5	0,4	0,4		
		in.lb	7,1	6,2	4,4	4,4	3,5	3,5		
Max. torsional backlash	j_t	arcmin	≤8							
Torsional rigidity	C_{I21}	Nm/arcmin	4,5							
		in.lb/arcmin	40							
Max. axial force ^{b)}	F_{2AMax}	N	3000							
		lb _f	675							
Max. radial force ^{b)}	F_{2RMMax}	N	2400							
		lb _f	540							
Max. tilting moment	M_{2KMMax}	Nm	205							
		in.lb	1814							
Service life <small>(For calculation see "Information")</small>	L_h	h	> 20000							
Weight incl. standard adapter plate	m	kg	4,0							
		lb _m	8,8							
Operating noise <small>(with $n_{IN}=3000$ rpm no load)</small>	L_{PA}	dB(A)	< 54							
Max. permitted housing temperature		°C	+90							
		F	194							
Ambient temperature		°C	-15 to +40							
		F	5 to 104							
Lubrication	Synthetic transmission oil									
Paint	None									
Direction of rotation	See drawing									
Protection class	IP 65									
Moment of inertia <small>(relates to the drive)</small>	C	14	J_i	kgcm ²	0.52	0.38	0.34	0.32	0.32	0.31
				10 ⁻³ in.lb.s ²	0.46	0.34	0.30	0.28	0.28	0.27
	E	19	J_i	kgcm ²	0.54	0.40	0.37	0.35	0.34	0.33
				10 ⁻³ in.lb.s ²	0.48	0.35	0.33	0.31	0.30	0.29

^{a)} Idling torques decrease during operation

^{b)} Refers to center of the output shaft or flange

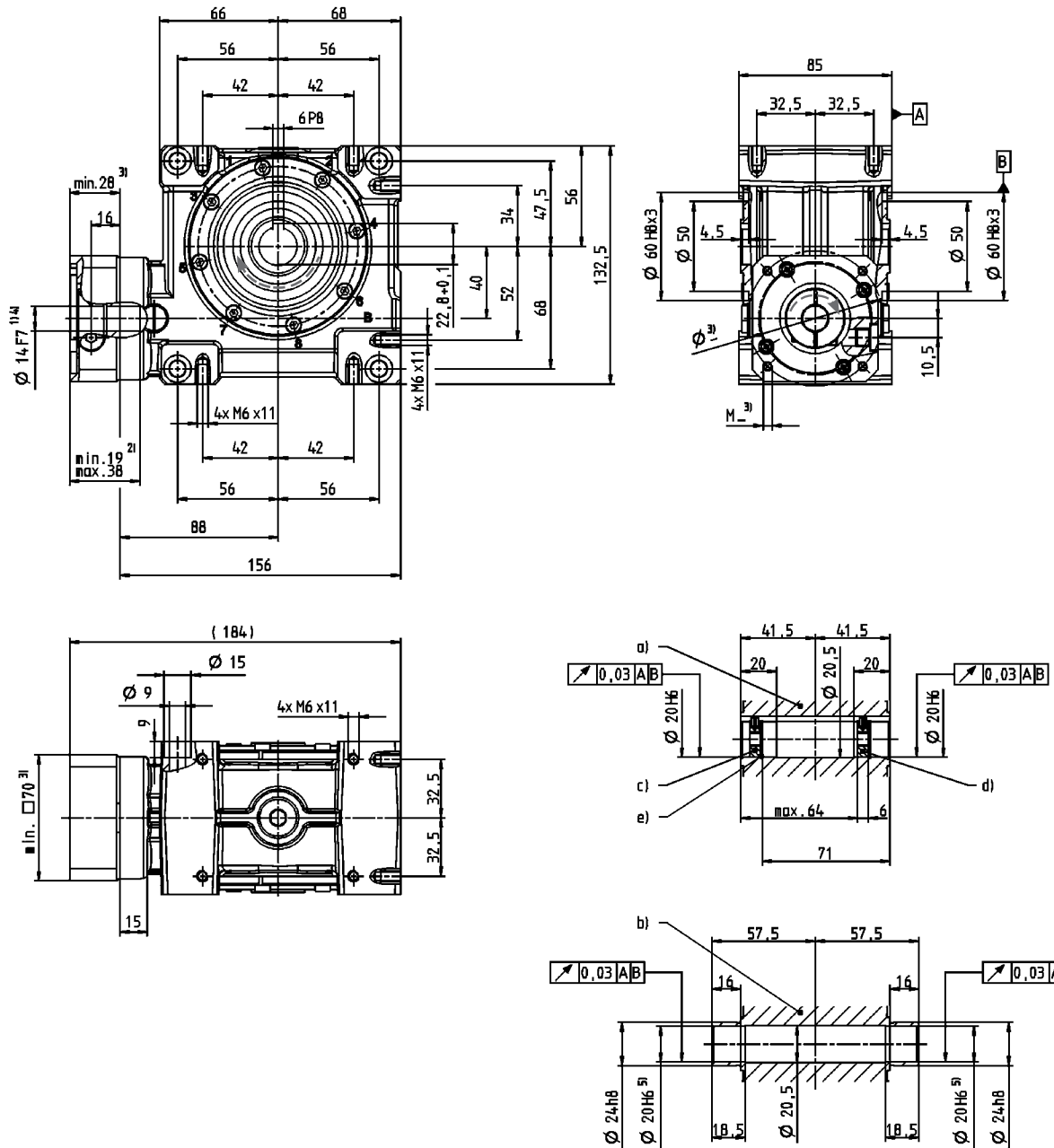

- a) Hollow shaft, keywayed
- b) Hollow shaft, smooth
- c) End disc for screw M6 (on request)
- d) End disc as forcing washer for screw M8 (on request)
- e) Locking ring – DIN 472

Non-tolerated dimensions ± 1 mm

- 1) Check motor shaft fit.
- 2) Min./Max. permissible motor shaft length.
Longer motor shafts are adaptable, please contact us.
- 3) The dimensions depend on the motor.
- 4) Smaller motor shaft diameter is compensated by a bushing with a minimum thickness of 1 mm. Motor shaft diameters up to 19 mm available – please contact WITTENSTEIN alpha.
- 5) Tolerance h6 for mounted shaft.

 CAD data is available under www.wittenstein-alpha.com

 Motor mounting according to operating manual

VDH economy 050 1-stage

			1-stage					
Ratio	<i>i</i>		4	7	10	16	28	40
$n_{1N}=500$ rpm	T_{2Max}	Nm	–	102	111	118	128	116
		in.lb	–	903	982	1044	1133	1027
	T_{2Servo}	Nm	–	62	64	70	78	64
		in.lb	–	549	566	620	690	566
	η	%	–	89	86	82	72	64
$n_{1N}=1000$ rpm	T_{2Max}	Nm	–	103	108	114	124	112
		in.lb	–	912	956	1009	1097	991
	T_{2Servo}	Nm	–	66	70	76	84	70
		in.lb	–	584	620	673	743	620
	η	%	–	91	89	85	77	69
$n_{1N}=2000$ rpm	T_{2Max}	Nm	–	92	97	105	117	103
		in.lb	–	814	858	929	1035	912
	T_{2Servo}	Nm	–	68	71	77	86	72
		in.lb	–	602	628	681	761	637
	η	%	–	93	91	88	75	75
$n_{1N}=3000$ rpm	T_{2Max}	Nm	–	82	88	97	105	95
		in.lb	–	726	779	858	929	841
	T_{2Servo}	Nm	–	67	70	76	84	70
		in.lb	–	593	620	673	743	620
	η	%	–	94	93	90	83	78
$n_{1N}=4000$ rpm	T_{2Max}	Nm	–	77	81	90	99	88
		in.lb	–	681	717	797	876	779
	T_{2Servo}	Nm	–	64	69	75	83	69
		in.lb	–	566	611	664	735	611
	η	%	–	95	93	91	85	80
Emergency stop torque	T_{2Not}	Nm	–	242	242	250	262	236
		in.lb	–	2142	2142	2213	2319	2089
Max. input speed	n_{1Max}	rpm	6000					
Mean no load running torque ^{a)} <small>(With $n_1=3000$ min⁻¹ and 20° C gear temperature)</small>	T_{012}	Nm	–	1,2	1,2	1,1	1	0,9
		in.lb	–	10,6	10,6	9,7	8,9	8,0
Max. torsional backlash	j_t	arcmin	≤8					
Torsional rigidity	C_{t21}	Nm/arcmin	8					
		in.lb/arcmin	71					
Max. axial force ^{b)}	F_{2AMax}	N	5000					
		lb _f	1125					
Max. radial force ^{b)}	F_{2RMMax}	N	3800					
		lb _f	855					
Max. tilting moment	M_{2KMMax}	Nm	409					
		in.lb	3620					
Service life <small>(For calculation see "Information")</small>	L_h	h	> 20000					
Weight incl. standardadapter plate	m	kg	7,4					
		lb _m	16,4					
Operating noise <small>(with $n_1=3000$ rpm no load)</small>	L_{PA}	dB(A)	≤ 62					
Max. permitted housing temperature		°C	+90					
		F	194					
Ambient temperature		°C	-15 to +40					
		F	5 to 104					
Lubrication	Synthetic transmission oil							
Paint	None							
Direction of rotation	See drawing							
Protection class	IP 65							
Moment of inertia <small>(relates to the drive)</small>	J_t	kgcm ²	–	2,02	1,93	1,84	1,81	1,86
		10 ⁻³ in.lb.s ²	–	1,79	1,71	1,63	1,60	1,64

^{a)} Idling torques decrease during operation

^{b)} Refers to center of the output shaft or flange

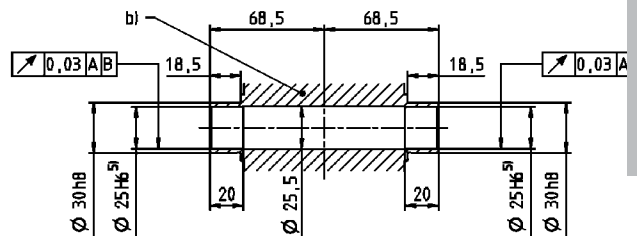
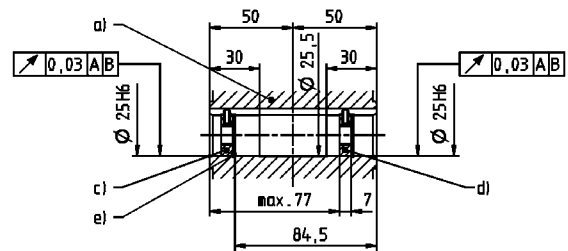
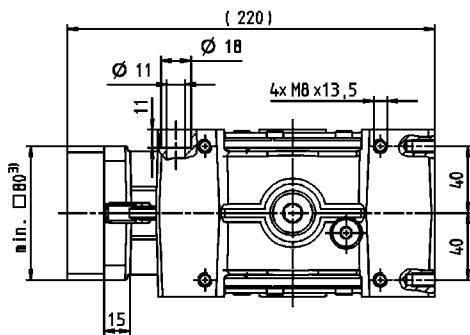
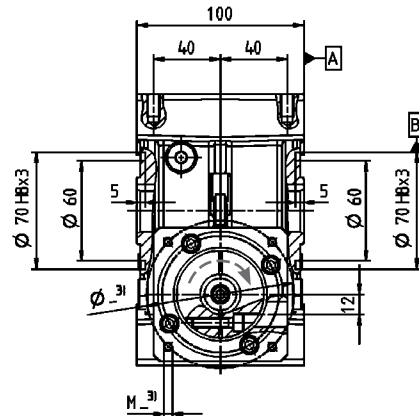
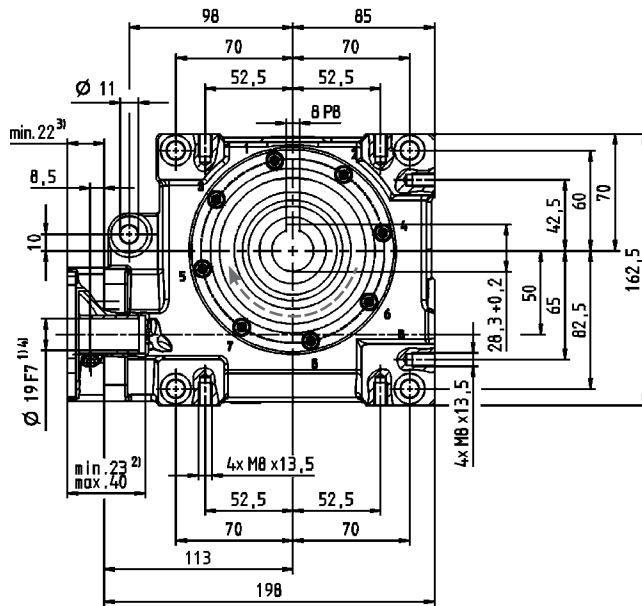

- a) Hollow shaft, keywayed
- b) Hollow shaft, smooth
- c) End disc for screw M10 (on request)
- d) End disc as forcing washer for screw M12 (on request)
- e) Locking ring – DIN 472 (on request)

Non-tolerated dimensions ± 1 mm

- 1) Check motor shaft fit.
- 2) Min./Max. permissible motor shaft length.
Longer motor shafts are adaptable, please contact us.
- 3) The dimensions depend on the motor.
- 4) Smaller motor shaft diameter is compensated by a bushing with a minimum thickness of 1 mm.
- 5) Tolerance h6 for mounted shaft.

CAD data is available under www.wittenstein-alpha.com

Motor mounting according to operating manual

VDH economy 063 1-stage

			1-stage					
Ratio	<i>i</i>		4	7	10	16	28	40
$n_{1N}=500$ rpm	T_{2Max}	Nm	–	264	270	279	301	282
		in.lb	–	2336	2390	2469	2664	2496
	T_{2Servo}	Nm	–	183	195	198	215	201
		in.lb	–	1620	1726	1752	1903	1779
η	%	–	91	88	83	74	68	
$n_{1N}=1000$ rpm	T_{2Max}	Nm	–	256	265	276	299	280
		in.lb	–	2266	2345	2443	2646	2478
	T_{2Servo}	Nm	–	197	208	212	230	215
		in.lb	–	1743	1841	1876	2036	1903
η	%	–	93	91	86	78	73	
$n_{1N}=2000$ rpm	T_{2Max}	Nm	–	234	252	263	277	269
		in.lb	–	2071	2230	2328	2451	2381
	T_{2Servo}	Nm	–	188	203	212	224	217
		in.lb	–	1664	1797	1876	1982	1920
η	%	–	94	93	89	83	78	
$n_{1N}=3000$ rpm	T_{2Max}	Nm	–	183	198	209	230	224
		in.lb	–	1620	1752	1850	2036	1982
	T_{2Servo}	Nm	–	145	163	181	182	177
		in.lb	–	1283	1443	1602	1611	1566
η	%	–	95	94	91	85	81	
$n_{1N}=4000$ rpm	T_{2Max}	Nm	–	146	162	175	196	193
		in.lb	–	1292	1434	1549	1735	1708
	T_{2Servo}	Nm	–	114	134	152	152	149
		in.lb	–	1009	1186	1345	1345	1319
η	%	–	96	94	92	86	83	
Emergency stop torque	T_{2Not}	Nm	–	484	491	494	518	447
		in.lb	–	4283	4345	4372	4584	3956
Max. input speed	n_{1Max}	rpm	4500					
Mean no load running torque ^{a)} <small>(With $n_1=3000$ min⁻¹ and 20° C gear temperature)</small>	T_{012}	Nm	–	1,9	1,8	1,7	1,6	1,4
		in.lb	–	16,8	15,9	15,0	14,2	12,4
Max. torsional backlash	j_t	arcmin	≤8					
Torsional rigidity	C_{t21}	Nm/arcmin	28					
		in.lb/arcmin	248					
Max. axial force ^{b)}	F_{2AMax}	N	8250					
		lb _f	1856					
Max. radial force ^{b)}	F_{2RMMax}	N	6000					
		lb _f	1350					
Max. tilting moment	M_{2KMMax}	Nm	843					
		in.lb	7461					
Service life <small>(For calculation see "Information")</small>	L_h	h	> 20000					
Weight incl. standardadapter plate	m	kg	12					
		lb _m	26,5					
Operating noise <small>(with $n_1=3000$ rpm no load)</small>	L_{PA}	dB(A)	≤ 64					
Max. permitted housing temperature		°C	+90					
		F	194					
Ambient temperature		°C	-15 to +40					
		F	5 to 104					
Lubrication	Synthetic transmission oil							
Paint	None							
Direction of rotation	See drawing							
Protection class	IP 65							
Moment of inertia <small>(relates to the drive)</small>	J_t	kgcm ²	–	5,77	5,53	5,44	5,40	5,35
		10 ⁻³ in.lb.s ²	–	5,11	4,89	4,81	4,78	4,74

^{a)} Idling torques decrease during operation

^{b)} Refers to center of the output shaft or flange

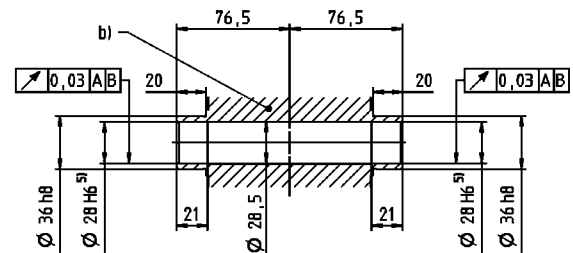
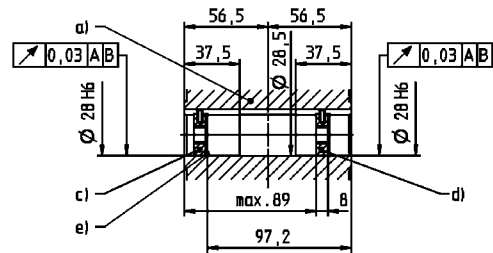
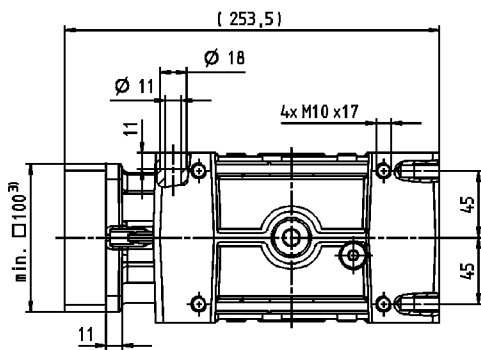
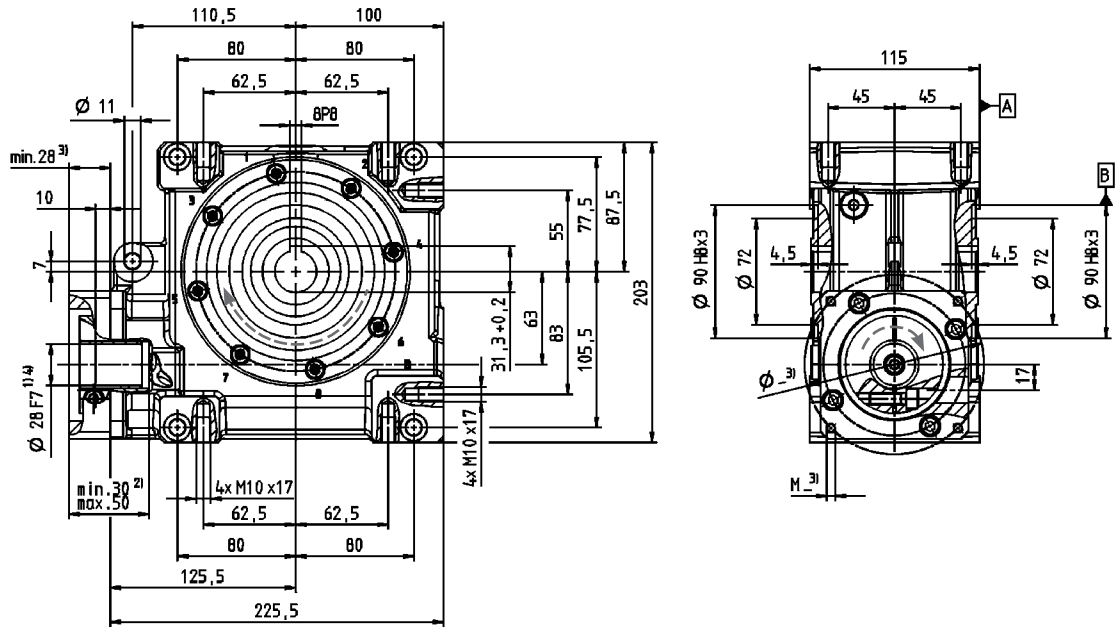

- a) Hollow shaft, keywayed
- b) Hollow shaft, smooth
- c) End disc for screw M10 (on request)
- d) End disc as forcing washer for screw M12 (on request)
- e) Locking ring – DIN 472 (on request)

Non-tolerated dimensions ± 1 mm

- 1) Check motor shaft fit.
- 2) Min./Max. permissible motor shaft length.
Longer motor shafts are adaptable, please contact us.
- 3) The dimensions depend on the motor.
- 4) Smaller motor shaft diameter is compensated by a bushing with a minimum thickness of 1 mm.
- 5) Tolerance h6 for mounted shaft.

CAD data is available under www.wittenstein-alpha.com

Motor mounting according to operating manual

VDS economy 040 1-stage

			1-stage							
Ratio	<i>i</i>		4	7	10	16	28	40		
$n_{1N}=500$ rpm	T_{2Max}	Nm	45	60	68	72	75	70		
		in.lb	398	531	602	637	664	620		
	T_{2Servo}	Nm	19	26	28	29	32	28		
		in.lb	168	230	248	257	283	248		
η	%		93	90	88	82	73	67		
$n_{1N}=1000$ rpm	T_{2Max}	Nm	45	60	68	72	75	70		
		in.lb	398	531	602	637	664	620		
	T_{2Servo}	Nm	19	26	28	29	32	28		
		in.lb	168	230	248	257	283	248		
η	%		94	92	90	86	77	73		
$n_{1N}=2000$ rpm	T_{2Max}	Nm	35	50	54	59	63	60		
		in.lb	310	443	478	522	558	531		
	T_{2Servo}	Nm	19	26	28	29	33	29		
		in.lb	168	230	248	257	292	257		
η	%		96	94	92	88	81	77		
$n_{1N}=3000$ rpm	T_{2Max}	Nm	30	42	46	51	53	52		
		in.lb	266	372	407	451	469	460		
	T_{2Servo}	Nm	19	26	28	29	32	28		
		in.lb	168	230	248	257	283	248		
η	%		96	95	93	90	83	79		
$n_{1N}=4000$ rpm	T_{2Max}	Nm	28	36	40	44	47	46		
		in.lb	248	319	354	389	416	407		
	T_{2Servo}	Nm	19	25	27	28	31	27		
		in.lb	168	221	239	248	274	239		
η	%		96	95	94	91	84	81		
Emergency stop torque	T_{2Not}	Nm	118	126	125	129	134	122		
		in.lb	1044	1115	1106	1142	1186	1080		
Max. input speed	n_{1Max}	rpm	6000							
Mean no load running torque ^{a)} <small>(With $n_1=3000$ min⁻¹ and 20° C gear temperature)</small>	T_{012}	Nm	0,8	0,7	0,5	0,5	0,4	0,4		
		in.lb	7,1	6,2	4,4	4,4	3,5	3,5		
Max. torsional backlash	j_t	arcmin	≤8							
Torsional rigidity	C_{t21}	Nm/arcmin	4,5							
		in.lb/arcmin	40							
Max. axial force ^{b)}	F_{2AMax}	N	3000							
		lb _f	675							
Max. radial force ^{b)}	F_{2RMMax}	N	2400							
		lb _f	540							
Max. tilting moment	M_{2KMMax}	Nm	205							
		in.lb	1814							
Service life <small>(For calculation see "Information")</small>	L_h	h	> 20000							
Weight incl. standardadapter plate	m	kg	4,1							
		lb _m	9,1							
Operating noise <small>(with $n_1=3000$ rpm no load)</small>	L_{PA}	dB(A)	≤ 54							
Max. permitted housing temperature	°C		+90							
	F		194							
Ambient temperature	°C		-15 to +40							
	F		5 to 104							
Lubrication	Synthetic transmission oil									
Paint	None									
Direction of rotation	See drawing									
Protection class	IP 65									
Moment of inertia <small>(relates to the drive)</small> <small>Moments of inertia for motor shaft diameter 14 and 19 mm</small>	C	14	J_i	kgcm ²	0.52	0.38	0.34	0.32	0.32	0.31
				10 ⁻³ in.lb.s ²	0.46	0.34	0.30	0.28	0.28	0.27
	E	19	J_i	kgcm ²	0.54	0.40	0.37	0.35	0.34	0.33
				10 ⁻³ in.lb.s ²	0.48	0.35	0.33	0.31	0.30	0.29

^{a)} Idling torques decrease during operation

^{b)} Refers to center of the output shaft or flange

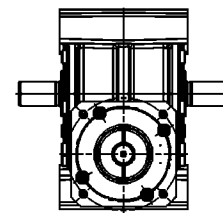
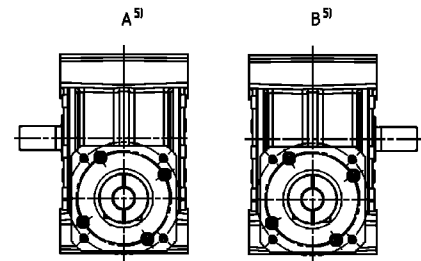
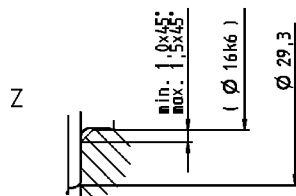
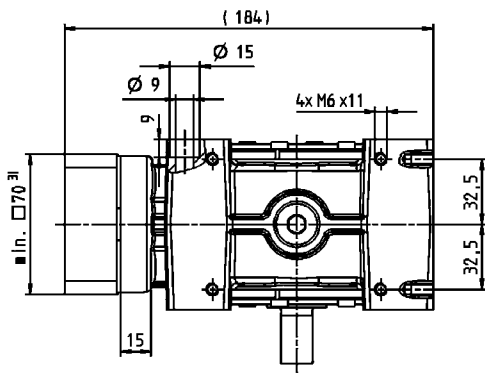
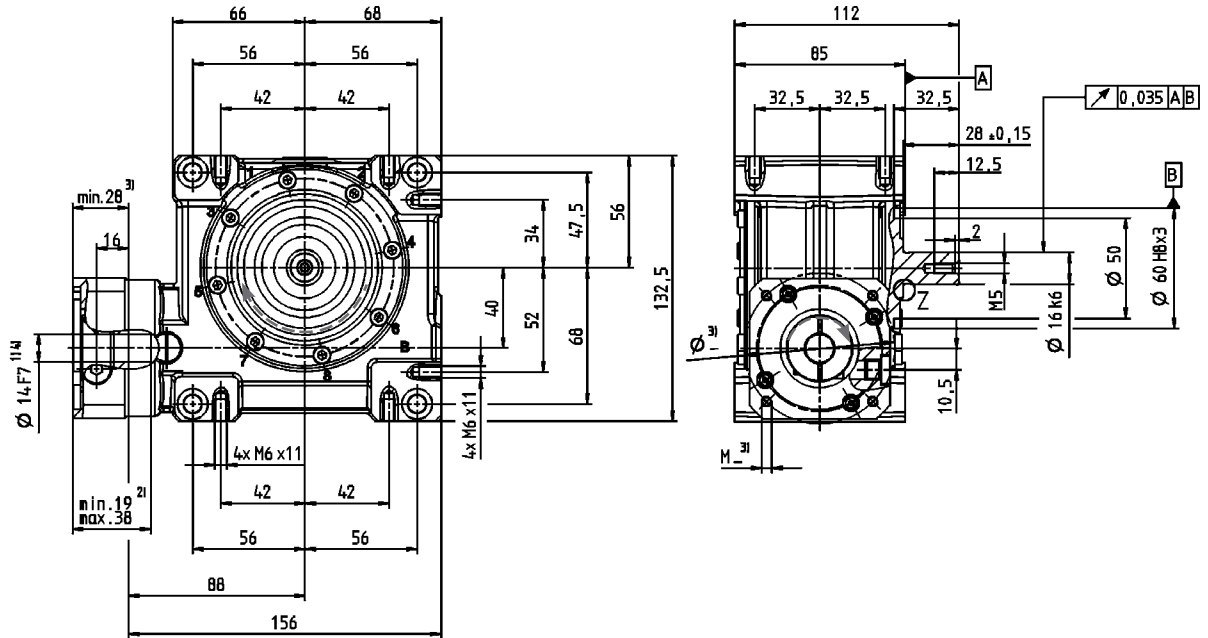

Optional dual-shaft output. Drawings available upon request.

Alternatives: Output shaft variants

Keywayed output shaft in mm
E = key as per DIN 6885, sheet 1, form A

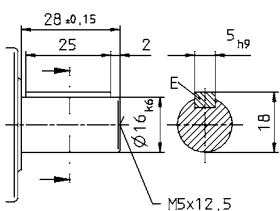

Non-tolerated dimensions ± 1 mm

- 1) Check motor shaft fit.
- 2) Min./Max. permissible motor shaft length.
Longer motor shafts are adaptable, please contact us.
- 3) The dimensions depend on the motor.
- 4) Smaller motor shaft diameter is compensated by a bushing with a minimum thickness of 1 mm. Motor shaft diameters up to 19 mm available – please contact WITTENSTEIN alpha
- 5) Output side

CAD data is available under www.wittenstein-alpha.com

Motor mounting according to operating manual

VDS economy 050 1-stage

			1-stage					
Ratio	<i>i</i>		4	7	10	16	28	40
$n_{1N}=500$ rpm	T_{2Max}	Nm	–	102	111	118	128	116
		in.lb	–	903	982	1044	1133	1027
	T_{2Servo}	Nm	–	62	64	70	78	64
		in.lb	–	549	566	620	690	566
	η	%	–	89	86	82	72	64
$n_{1N}=1000$ rpm	T_{2Max}	Nm	–	103	108	114	124	112
		in.lb	–	912	956	1009	1097	991
	T_{2Servo}	Nm	–	66	70	76	84	70
		in.lb	–	584	620	673	743	620
	η	%	–	91	89	85	77	69
$n_{1N}=2000$ rpm	T_{2Max}	Nm	–	92	97	105	117	103
		in.lb	–	814	858	929	1035	912
	T_{2Servo}	Nm	–	68	71	77	86	72
		in.lb	–	602	628	681	761	637
	η	%	–	93	91	88	75	75
$n_{1N}=3000$ rpm	T_{2Max}	Nm	–	82	88	97	105	95
		in.lb	–	726	779	858	929	841
	T_{2Servo}	Nm	–	67	70	76	84	70
		in.lb	–	593	620	673	743	620
	η	%	–	94	93	90	83	78
$n_{1N}=4000$ rpm	T_{2Max}	Nm	–	77	81	90	99	88
		in.lb	–	681	717	797	876	779
	T_{2Servo}	Nm	–	64	69	75	83	69
		in.lb	–	566	611	664	735	611
	η	%	–	95	93	91	85	80
Emergency stop torque	T_{2Not}	Nm	–	242	242	250	262	236
		in.lb	–	2142	2142	2213	2319	2089
Max. input speed	n_{1Max}	rpm	6000					
Mean no load running torque ^{a)} <small>(With $n_1=3000$ min⁻¹ and 20° C gear temperature)</small>	T_{012}	Nm	–	1,2	1,2	1,1	1	0,9
		in.lb	–	10,6	10,6	9,7	8,9	8,0
Max. torsional backlash	j_t	arcmin	≤8					
Torsional rigidity	C_{t21}	Nm/arcmin	8					
		in.lb/arcmin	71					
Max. axial force ^{b)}	F_{2AMax}	N	5000					
		lb _f	1125					
Max. radial force ^{b)}	F_{2RMMax}	N	3800					
		lb _f	855					
Max. tilting moment	M_{2KMMax}	Nm	409					
		in.lb	3620					
Service life <small>(For calculation see "Information")</small>	L_h	h	> 20000					
Weight incl. standardadapter plate	m	kg	7,7					
		lb _m	17,0					
Operating noise <small>(with $n_1=3000$ rpm no load)</small>	L_{PA}	dB(A)	≤ 62					
Max. permitted housing temperature		°C	+90					
		F	194					
Ambient temperature		°C	-15 to +40					
		F	5 to 104					
Lubrication	Synthetic transmission oil							
Paint	None							
Direction of rotation	See drawing							
Protection class	IP 65							
Moment of inertia <small>(relates to the drive)</small>	J_t	kgcm ²	–	2,01	1,93	1,84	1,81	1,86
		10 ⁻³ in.lb.s ²	–	1,78	1,71	1,63	1,60	1,64

^{a)} Idling torques decrease during operation

^{b)} Refers to center of the output shaft or flange

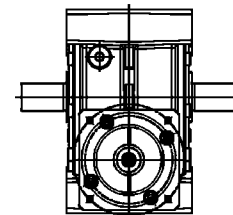
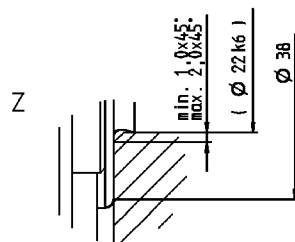
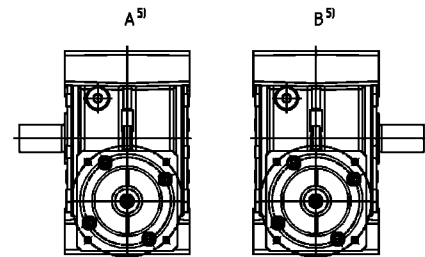
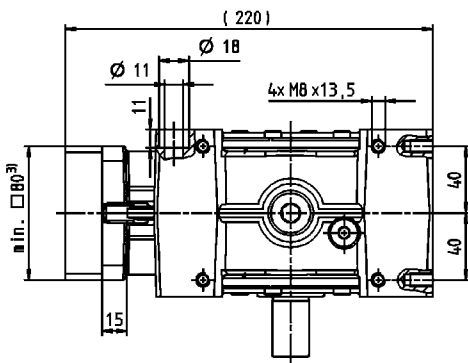
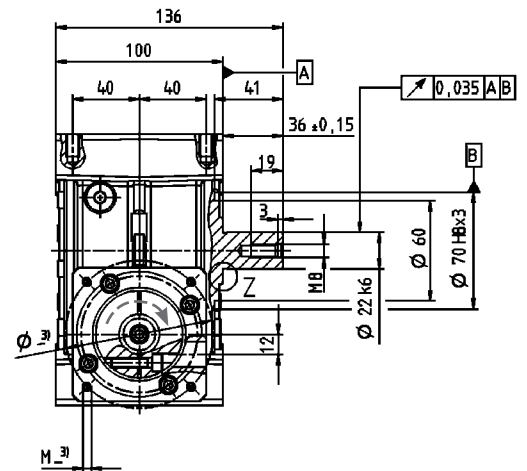
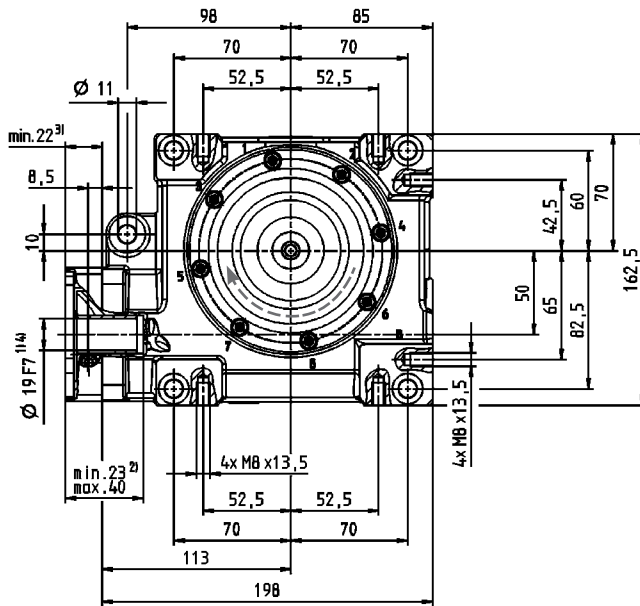

Optional dual-shaft output. Drawings available upon request.

Alternatives: Output shaft variants

Keywayed output shaft in mm
E = key as per DIN 6885, sheet 1, form A

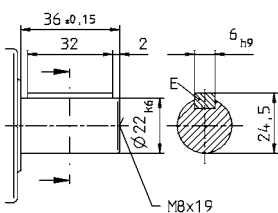

Non-tolerated dimensions ± 1 mm

- 1) Check motor shaft fit.
- 2) Min./Max. permissible motor shaft length.
Longer motor shafts are adaptable, please contact us.
- 3) The dimensions depend on the motor.
- 4) Smaller motor shaft diameter is compensated by a bushing with a minimum thickness of 1 mm.
- 5) Output side

CAD data is available under www.wittenstein-alpha.com

Motor mounting according to operating manual

VDS economy 063 1-stage

			1-stage					
Ratio	<i>i</i>		4	7	10	16	28	40
$n_{1N}=500$ rpm	T_{2Max}	Nm	–	264	270	279	301	282
		in.lb	–	2336	2390	2469	2664	2496
	T_{2Servo}	Nm	–	183	195	198	215	201
		in.lb	–	1620	1726	1752	1903	1779
η	%		–	91	88	83	74	68
$n_{1N}=1000$ rpm	T_{2Max}	Nm	–	256	265	276	299	280
		in.lb	–	2266	2345	2443	2646	2478
	T_{2Servo}	Nm	–	197	208	212	230	215
		in.lb	–	1743	1841	1876	2036	1903
η	%		–	93	91	86	78	73
$n_{1N}=2000$ rpm	T_{2Max}	Nm	–	234	252	263	277	269
		in.lb	–	2071	2230	2328	2451	2381
	T_{2Servo}	Nm	–	188	203	212	224	217
		in.lb	–	1664	1797	1876	1982	1920
η	%		–	94	93	89	83	78
$n_{1N}=3000$ rpm	T_{2Max}	Nm	–	183	198	209	230	224
		in.lb	–	1620	1752	1850	2036	1982
	T_{2Servo}	Nm	–	145	163	181	182	177
		in.lb	–	1283	1443	1602	1611	1566
η	%		–	95	94	91	85	81
$n_{1N}=4000$ rpm	T_{2Max}	Nm	–	146	162	175	196	193
		in.lb	–	1292	1434	1549	1735	1708
	T_{2Servo}	Nm	–	114	134	152	152	149
		in.lb	–	1009	1186	1345	1345	1319
η	%		–	96	94	92	86	83
Emergency stop torque	T_{2Not}	Nm	–	484	491	494	518	447
in.lb		–	4283	4345	4372	4584	3956	
Max. input speed	n_{1Max}	rpm	4500					
Mean no load running torque ^{a)} <small>(With $n_1=3000$ min⁻¹ and 20° C gear temperature)</small>	T_{012}	Nm	–	1,9	1,8	1,7	1,6	1,4
		in.lb	–	16,8	15,9	15,0	14,2	12,4
Max. torsional backlash	j_t	arcmin	≤8					
Torsional rigidity	C_{t21}	Nm/arcmin	28					
		in.lb/arcmin	248					
Max. axial force ^{b)}	F_{2AMax}	N	8250					
		lb _f	1856					
Max. radial force ^{b)}	F_{2RMMax}	N	6000					
		lb _f	1350					
Max. tilting moment	M_{2KMMax}	Nm	843					
		in.lb	7461					
Service life <small>(For calculation see "Information")</small>	L_h	h	> 20000					
Weight incl. standard adapter plate	m	kg	12,5					
		lb _m	27,6					
Operating noise <small>(with $n_1=3000$ rpm no load)</small>	L_{PA}	dB(A)	≤ 64					
Max. permitted housing temperature	°C		+90					
	F		194					
Ambient temperature	°C		-15 to +40					
	F		5 to 104					
Lubrication	Synthetic transmission oil							
Paint	None							
Direction of rotation	See drawing							
Protection class	IP 65							
Moment of inertia <small>(relates to the drive)</small>	J_t	kgcm ²	–	5,78	5,53	5,44	5,40	5,35
		10 ⁻³ in.lb.s ²	–	5,12	4,90	4,82	4,78	4,74

^{a)} Idling torques decrease during operation

^{b)} Refers to center of the output shaft or flange

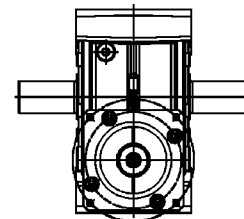
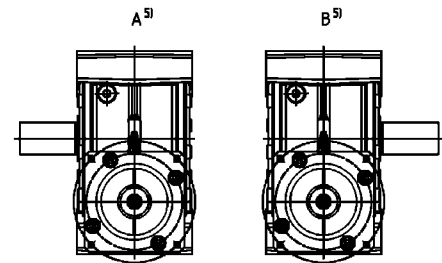
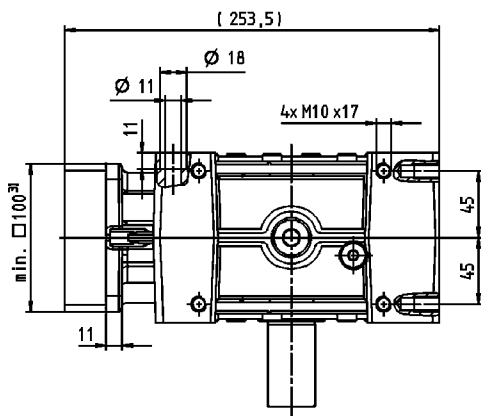
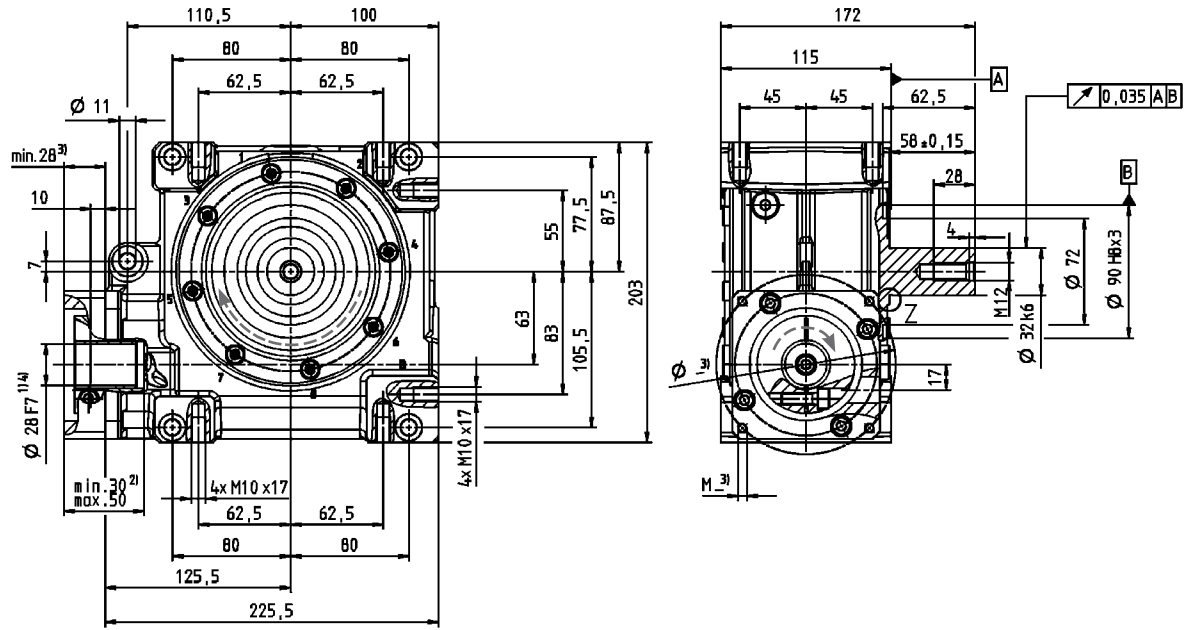

Optional dual-shaft output. Drawings available upon request.

Alternatives: Output shaft variants

Keywayed output shaft in mm
E = key as per DIN 6885, sheet 1, form A

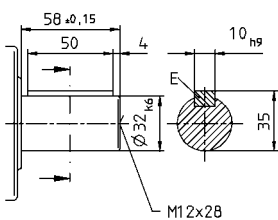

Non-tolerated dimensions ± 1 mm

- 1) Check motor shaft fit.
- 2) Min./Max. permissible motor shaft length. Longer motor shafts are adaptable, please contact us.
- 3) The dimensions depend on the motor.
- 4) Smaller motor shaft diameter is compensated by a bushing with a minimum thickness of 1 mm.
- 5) Output side

CAD data is available under www.wittenstein-alpha.com

Motor mounting according to operating manual

System solutions



alpha rack & pinion system

Precise rack and pinion drives tailored to your applications

We provide you with an optimum system solution comprising a gearhead, rack and pinion precisely tailored to your requirements. A selected range of accessories for lubrication and mounting complete the linear system.

www.rack-pinion.com



Lubrication

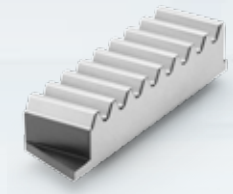

Assembly jig

Your benefits:

Dynamic

- Maximum movement speed and acceleration with low moments of inertia
- Excellent control characteristics due to constant linear rigidity along the entire movement path

Precise

- Drive solutions with unique true running accuracy
- Maximum positioning accuracy due to precision alignment of components

Efficient

- Effortless commissioning
- Minimal mounting space and high power density
- Huge savings potential



alpha IQ

Low backlash planetary gearboxes with integrated sensors

Achieving compatibility.
Utilizing intelligence.
Increasing efficiency.

WITTENSTEIN alpha gearhead with integrated sensors – helping you better understand your processes.

torqXis sensors

Modular intelligent sensor solution for measuring mechanical parameters in the drive train.

A window to the process:
Innovative systems are the result of in-depth process analysis – the decisive factor for understanding, monitoring and control of drive components.

Our services

- Customer-specific sensor solutions
- Empirical drive design
- On-site service
- Rental systems
- Measurement service

Your benefits:

- Energy-efficient drive control
- Dimensioning of drives
- Process-integrated monitoring of relevant process parameters
- Effective design optimization
- Effortless integration in the drive train
- Robust measurement tool (IP65)

System solutions

	Rack and pinion system
	alpha IQ
	torqXis